

New!



Introducing the Artex ME-406 Emergency Locator Transmitter

SMALLEST
& LIGHTEST
406 ELT IN THE
INDUSTRY!



ARTEX AIRCRAFT SUPPLIES
P.O. Box 1270
Canby, OR 97013
email: info@artex.net
www.artex.net

- Immediate search and rescue response
- Position accuracy within 3 km
- Transmitter is identified by serial number or aircraft ID
- Worldwide coverage
- Starts below \$1000 for complete package
- 5-year battery life LiSO₂ / LiMnO₂
- TSO-C126, ETSO-2C126 pending, COSPAS/SARSAT approved
- Mounting holes compatible with most existing ELT housings
- Single antenna output for both frequencies.

- Designed especially for the private pilot!
- 20 years of ELT design experience results in a breakthrough in design
- A low cost solution to 406Mhz technology requirements
- 121.5 and 406 MHz
- ELT weight: 2 lbs.

Actual Size:
6.6" x 3.7" x 2.9"



Learn more about the Artex ME-406 ELT by calling us at 1.800.547.8901 or visiting our web site at www.artex.net

560-6603 Rev -
04-01-05

SPECIFICATIONS:

Operating Frequencies:

406 MHz \pm 1 kHz Biphase L (16K0G1D)
121.5 MHz \pm 0.005% (A3X)

Output Power:

406 MHz: 5 W (440 ms / 50 sec) for 24 hours @ -20° C to +55° C
121.5 MHz: 100 mW min for 50 hours @ -20° C to +55° C

Output Connector:

BNC Female

Activation:

Automatic by 4.5 ft/sec G-Switch or Manual

Battery:

5 year Lithium (LiSO₂, LiMnO₂)

Temperature:

Operating: -20° C to +55° C
Storage: -55° C to +85° C

Self Test:

G-Switch enabled
406 MHz Power
121.5 MHz Power
Antenna/Coax Connection
Low Battery

Remote Control:

ON/ARM/RESET

Antenna:

Rod (110-338) (<350 KTS)
Whip (110-773) (<200 KTS)

Mounting Hardware:

Mounting Tray P/N 452-3034

Other Parts:

Coax cable
Buzzer (to alert ground crews of accidental activation)

Weights:

ELT Transmitter: 1.85 lbs (833 g)
Mounting Tray: 3.52 oz (100 g)
Total Weight: 2.05 lbs (933 g)

Measurements:

ELT Transmitter with Mounting Hardware Installed:
6.59" (167 mm) L x 2.86" (73 mm) H
x 3.69" (94 mm) W

Part Numbers:

ME-406: 453-6603
(Transmitter Only)

Artex ME-406 Series

The Artex **ME-406** is a single output ELT. Two emergency frequencies (121.5 and 406.028 MHz) utilize the same RF output, which requires only one coax cable to connect to the new series of Artex single input antennas. The ELT automatically activates during a crash and transmits the standard swept tone on 121.5 MHz.

Every 50 seconds for 440 milliseconds the 406 MHz transmitter turns on and transmits an encoded digital message to the Cospas/Sarsat satellite system. The mounting hardware for the ME-406 Series is compatible with all previous models of Artex 406 MHz, as well as the ELT200 Series, Pointer Model 3000 ELT and Narco ELT's.

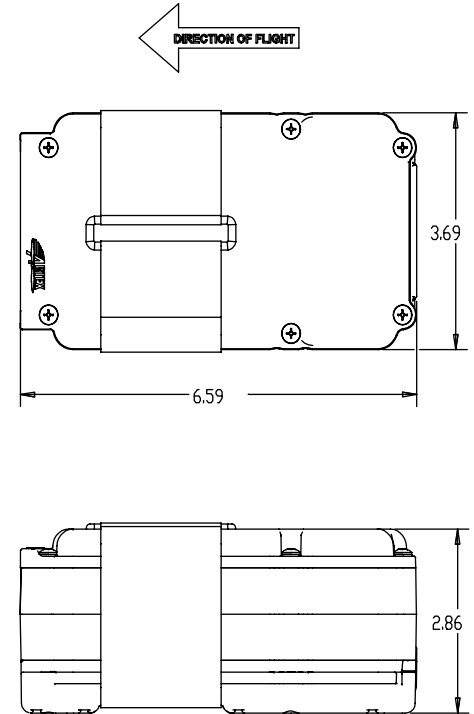
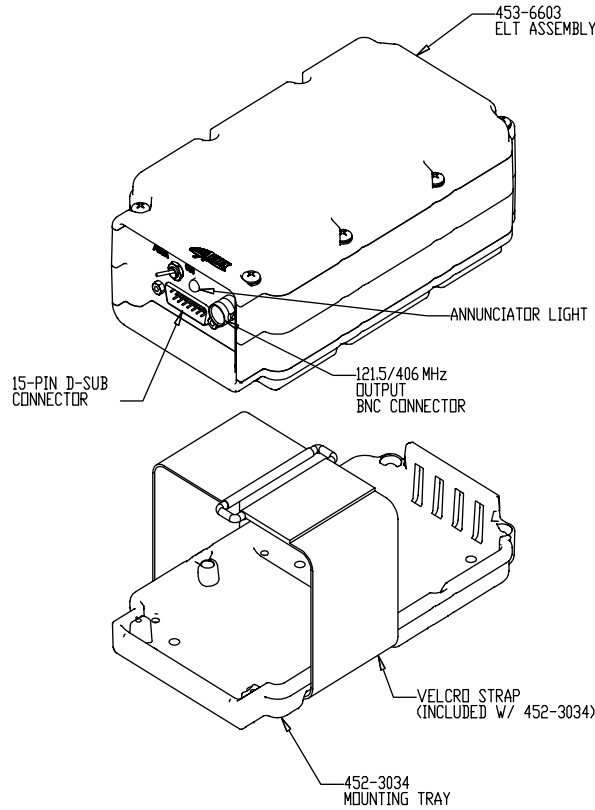

ELT OUTLINE DRAWING (Dimensions shown in inches)



"Saving Lives"

ARTEX AIRCRAFT SUPPLIES
P.O. Box 1270
Canby, OR 97013
email: info@artex.net
www.artex.net

Learn more about the Artex ME-406 ELT by calling us at 1.800.547.8901 or visiting our web site at www.artex.net

560-6603 Rev -
04-01-05